



TORIT[®] INSTALLATION AND OPERATION MANUAL

FOR TORIT FILTER CARTRIDGE SYSTEM DUST COLLECTORS
Torit Downflo Models 2DF8, 2DF12, 2DF16
3DF24, 3DF36, 3DF60, 3DF72,
4DF32, 4DF48, 4DF64, 4DF80

Includes Installation, Operation, Service Instructions, and Parts List

WITH QUICK-
CHANGE FILTER
ELEMENTS



IMPORTANT

This manual contains specific precautionary statements relative to worker safety in appropriate sections. Read this manual thoroughly and comply as directed. It is impossible to list all of the potential hazards of dust control equipment. It is imperative that use of the equipment be discussed with a TORIT representative. Personnel involved with the equipment or systems should be instructed to conduct themselves in a safe manner.

CAUTION

APPLICATION OF DUST CONTROL EQUIPMENT

- Avoid mixing combustible materials such as buffing lint, paper, wood, dust, aluminum, and magnesium with dust generated from grinding ferrous metals due to the potential fire hazard caused by sparks in the dust collector.
- Under no conditions should the machine operator be allowed to put lit cigarettes or any burning object into the hood or ducting of any dust control system.
- A prudent user of TORIT equipment should consult and comply with all National and Local Fire Codes and/or other appropriate codes when determining the location and operation of dust collector equipment.
- When dust collectors are used to collect flammable or explosive dust, the dust collector should be located outside the building. Also, an installer of fire extinguishing equipment, familiar with this type of fire hazard and local fire codes should be consulted for recommendations and installation of the proper fire extinguishing equipment. Dust collectors do not contain fire extinguishing equipment.
- Explosion vents are required on some applications. Consult with an insurance underwriter or a NFPA Manual to determine proper vent size ratio. Vents installed on dust control equipment within a building must be vented to the outside to minimize chances of a secondary explosion. Consult the proper authority to determine proper method of venting. Dust collectors do not contain explosion relief vents except on special order.



Donaldson Company, Inc.
Donaldson Industrial Group

TORIT Division of Donaldson Company, Inc., is the leading designer and manufacturer of dust collector systems for the control of industrial air pollution. Its systems are designed to help reduce occupational hazards, lengthen machine life, reduce in-plant maintenance requirements, and improve product quality.

TABLE OF CONTENTS

| | |
|---|-----|
| Notes and Cautions | 2 |
| Data Sheet | 3 |
| Introduction | 4 |
| Operational Explanation | 4 |
| Inspection | 4 |
| Pre-Installation | 6 |
| Installation | 6-7 |
| Electrical | 7 |
| Solid State Timer Specifications | 8 |
| Air Supply | 8 |
| Operation | 8-9 |
| Start-Up | 8 |
| Operating Checks | 9 |
| Operating Adjustments | 9 |
| Service | 9 |
| Filter Element Removal/Installation | 10 |
| Replacement Parts List | 13 |
| Parts Ordering Information | 14 |
| Warranty | 14 |

FIGURES

| | |
|---|----|
| Figure 1 - Operational Schematic | 4 |
| Figure 2 - Typical Installation | 5 |
| Figure 3 - T.D. Solid State Wiring Diagram | 6 |
| Figure 4 - Leg Positioning & Crossbracing | 7 |
| Figure 5 - Operating Logic Diagram | 8 |
| Figure 6 - Filter Element Replacement | 9 |
| Parts Drawing 1 - Downflo Dust Collector | 11 |
| Parts Drawing 2 - Air Manifold Detail | 12 |
| Parts Drawing 3 - Bolting Detail - Hopper to Cabinet | 12 |
| Parts Drawing 4 - Bolting Detail - Legs to Cabinet | 12 |

DATA SHEET

| | | | |
|---------------|-------|-------------------|-------|
| Customer Name | _____ | | |
| Address | _____ | | |
| Shipping Date | _____ | Installation Date | _____ |
| Model Number | _____ | Serial Number | _____ |
| Filter Medium | _____ | | |
| Accessories | _____ | | |
| Other | _____ | | |

INTRODUCTION

The Torit Downflo Dust Collector is used for collection of airborne dust and particulate. Whether in answer to the problem of air pollution or as part of a manufacturing process, the Downflo provides continuous on-line operation.

Filter elements are cleaned automatically and sequentially. The result is that only a small portion of the filter cartridges may be off-line for cleaning at any given time. Elements are installed end to end in pairs, nearly horizontal. Element dimensions are 12-3/4" OD, 8-3/8" ID by 26" long.

Operational Explanation (See Figure 1 – Operational Schematic)

During normal operation air enters the Downflo dust collector through the top inlet and passes through the filter elements. Dust is collected on the outside surfaces of the elements and clean air flows through the center of the elements into the clean air plenum where it exits through the clean air outlet.

During filter element purge the solid state control timer automatically selects the pair of elements to be cleaned and activates a solenoid valve which opens an air diaphragm valve. High pressure air pulses directly into the center of the selected elements for 100 milliseconds, blowing the collected dust off the filter elements. The dust is swept downward into the hopper by the prevailing air flow and by gravity.

NOTE

An inlet in each module is strongly recommended to optimize the Downflo's performance.

INSPECTION

The Downflo dust collector is normally shipped by flat bed truck and should be checked for any damage that may have occurred en route. Any damage should be noted and the carrier notified within 24 hours.

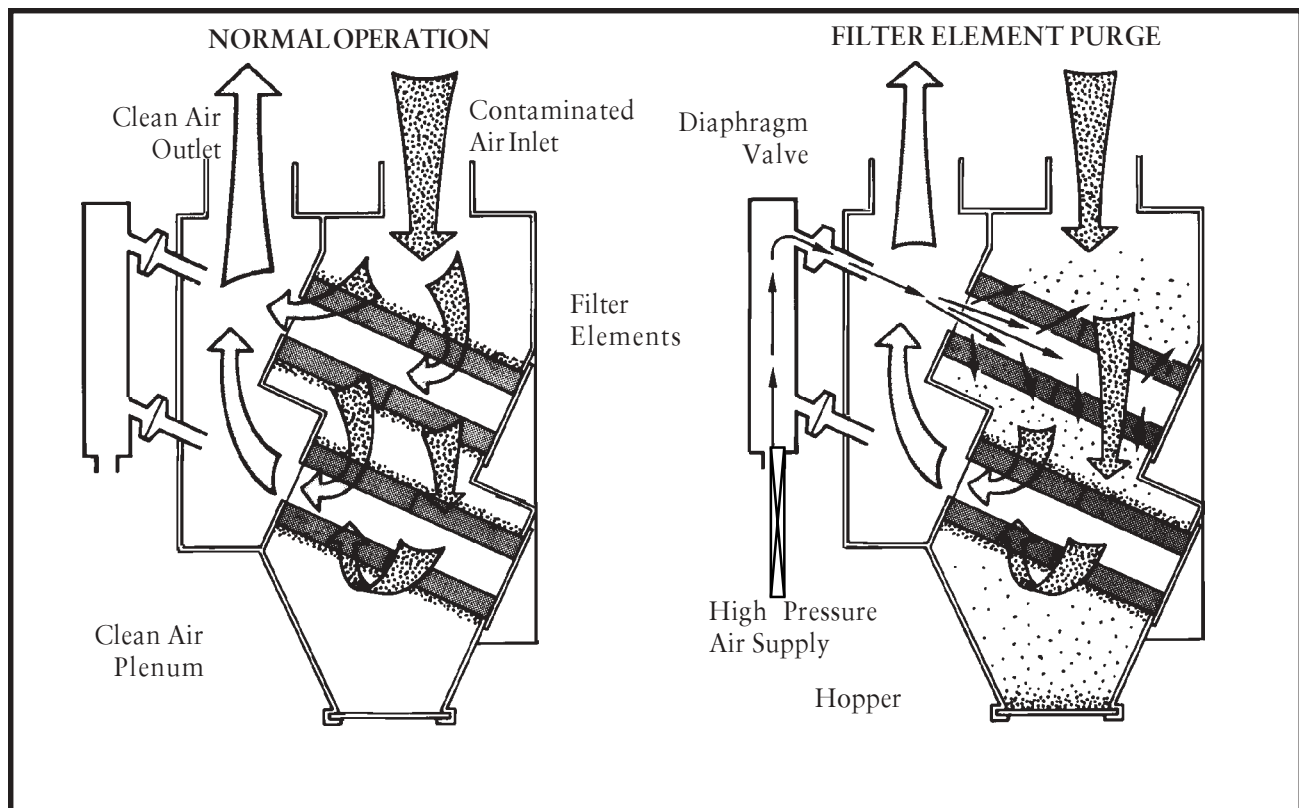

Figure 1
Operational Schematics

NOTE: Asterisked items (*) are not included with dust collector.

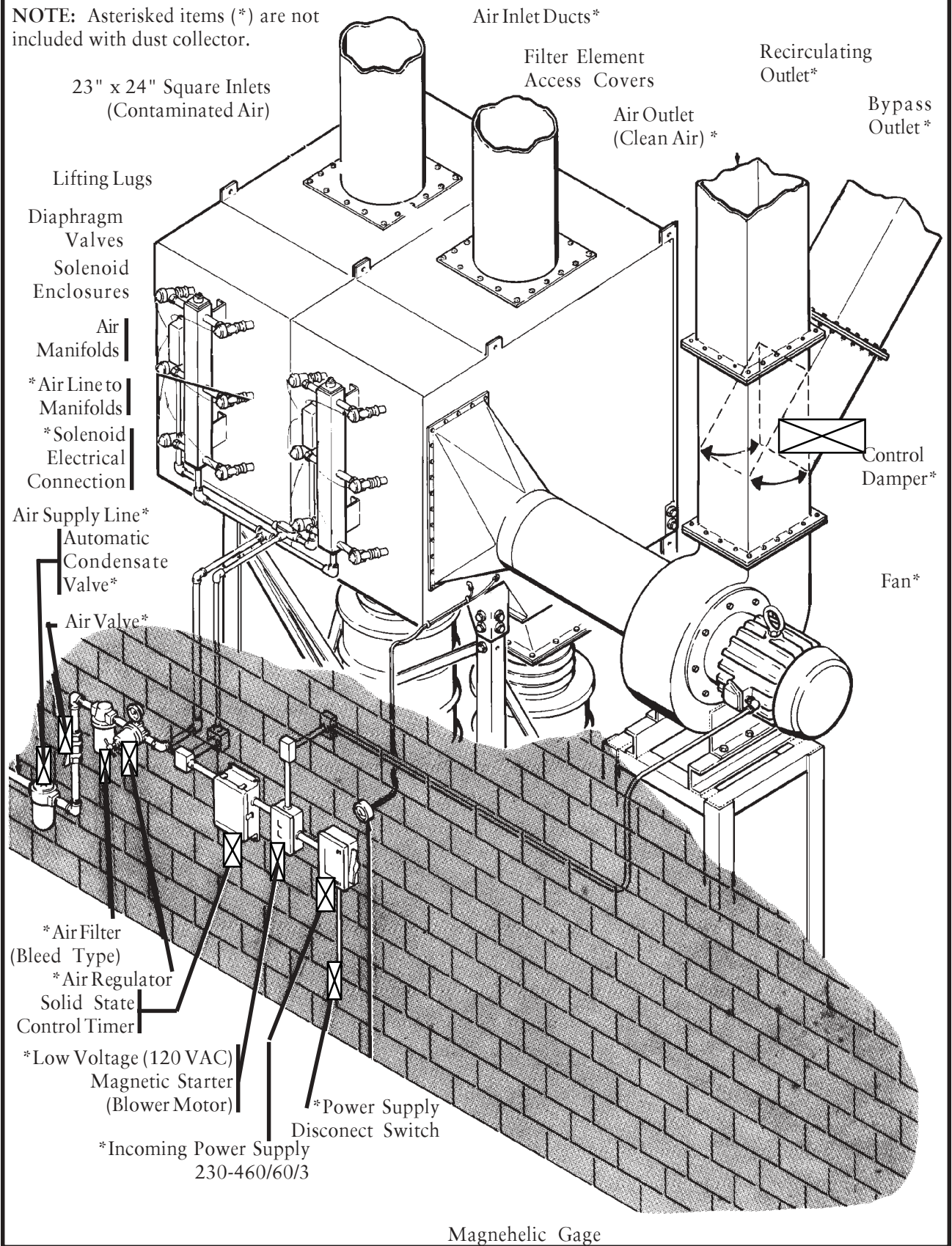

Figure 2
Typical Installation

PRE-INSTALLATION

The Downflo model dust collector is usually mounted on a reinforced concrete foundation. However, roof mounting is also possible. When calculating for foundation or roof mounting, the weight of the dust collector, material collected and all auxiliary equipment must be considered together with wind and seismic loads. See individual Specification Control Drawings for dust collector weight.

CAUTION

Location must be clear of all obstructions such as utility lines or overhang (see Specification Control Drawing) as a crane must be used to move the collector into position.

To avoid delay, install foundation in the proper location, with particular attention given to anchor bolt location. See Specification Control Drawing for anchor bolt location. Anchor bolts must extend at least 1-3/4" above foundation. The collector should be located with consideration for emptying the hopper, shortest run for location of duct work, electrical and air connections, and maintenance. In the case of hazardous dust, consult with local authorities for the location of the unit.

INSTALLATION

(See Figure 2 – Typical Installation and Parts Drawings, pages 9 & 10)

A crane is recommended for unloading, assembly and installation of the dust collector.

CAUTION

- Connect lifting sling to at least four cabinet lifting lugs – distribute load evenly.
- Connecting lifting sling to double-thickness cabinet lifting lugs when possible.
- Use clevises, not hooks, on lifting sling.
- Use spreader bars on lifting sling.

Remove all crating and strapping from the unit. Remove all miscellaneous parts, (magnehelic gage, bolts, nuts, etc.) before lifting unit off the truck.

Stand hopper(s) on their discharge (hopper outlet), and apply sealant to hopper flanges inside bolt holes.

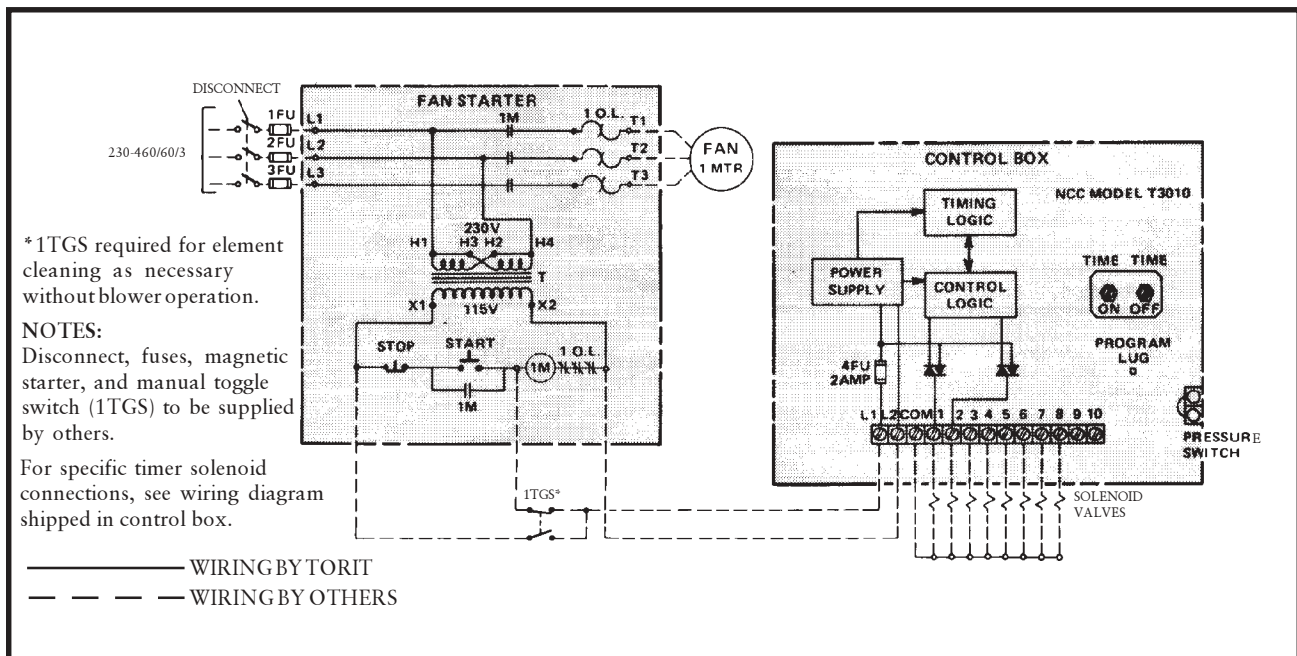

Figure 3
T.D. Solid State Wiring Diagram (2DF16 shown)

Lift cabinet from the truck, position over hopper(s) and bolt cabinet and hopper(s) together with grade 2 3/8 x 1-1/2" bolts, flatwashers, lockwashers, and nuts as shown on Bolting Detail – Hopper to Cabinet, page 10.

CAUTION
DO NOT DISCONNECT CRANE.

Attach legs – all legs are the same, however, they must be located in the proper position as shown in Figure 3. Also, leg cross-bracing must be located as shown in Figure 3. Lift the entire cabinet/hopper assembly and attach legs with grade 5, 3/4 x 1-3/4" bolts, flatwashers, lockwashers, and nuts – do not tighten bolts. See Bolting Detail – Legs to Cabinet, page 10.

Attach leg crossbraces at rear of dust collector with grade 5, 3/4 x 1-3/4" bolts, flatwashers lockwashers, and nuts. See Figure 3 and Bolting Detail – Leg Crossbracing, page 9 – do not tighten bolts.

Lift the assembled unit onto foundation anchor bolts. **TIGHTEN ALL LEG AND CROSSBRACING BOLTS.** Also fasten unit down to anchor bolts with flatwashers, lockwashers, and nuts and remove crane.

Position and install magnehelic gage for maximum readability per instructions supplied with gage. Magnehelic gage may be remotely mounted (see Figure 2), or mounted on dust collector as shown on Parts Drawing page 9. **NOTE:** Pressure taps for magnehelic gage are factory installed.

Install blower and inlet/outlet ducting. See Figure 2– Typical Installation.

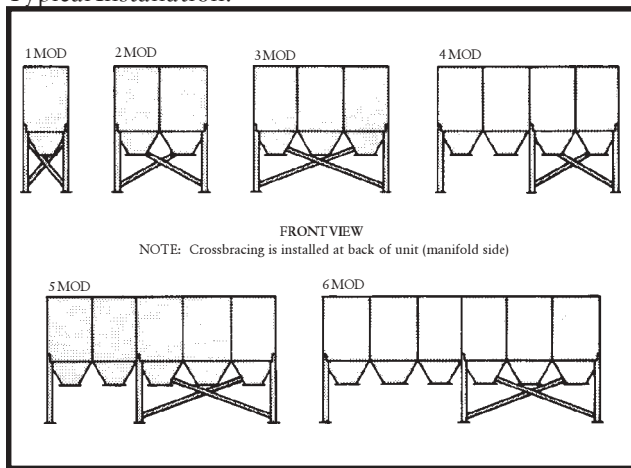

Figure 4
Leg Positioning and Crossbracing

ELECTRICAL

NOTE

All electrical work must be done by a qualified electrician according to local codes.

Install proper sized starter, (with low voltage control circuit) conduit and wires for blower motor.

Mount Downflo solid state control timer box near starter. **DO NOT MOUNT ON DUST COLLECTOR.**

Using wiring diagram, (inside control timer cover) make proper connections to blower motor, blower motor starter, solid state timer and solenoid valves. See Figure 4 for general wiring diagram.

NOTE

In grounded systems, neutral to control box must be connected to L2 of control box terminal board.

Start fan motor and check for proper rotation. Proper fan rotation is extremely important. Even if the fan is running the wrong direction it will deliver approximately 40% of its rated air volume, but it will require more than its rated horsepower. Reverse any two leads (3 phase only) on the load side of the fan motor starter to reverse fan rotation.

Check operation of the solenoid valves. These valves should open and close continuously with a factory set dwell between each pulse.

NOTE

If a Photohelic or similiar remote control device is sued as a internal control, valves will pulse only when pressure reaches set point.

Solid State Timer Specifications

NOTE

Solid State Downflo control requires a low voltage (120V) control circuit in fan starter to be supplied by others.

OPERATING LOGIC: Input power is applied to L1 and L2 of the timer control circuit board which is in parallel with the low voltage (120/60/1) coil of the fan magnetic starter. Upon fan start up, power is supplied to the control board and the preset "OFF" time is initiated. At the end of the "OFF" time the control will energize a solenoid to provide the cleaning pulse for one segment of filter elements and then step to the next segment. This cycle is continuous unless an auxiliary control such as a pressure switch, is used to control the timer. When all of the available outputs are not required, programming the control for fewer outputs is accomplished by resetting the program selection jumper. See Figure 5 – Operating Logic Diagram.

INOUT: 105-135 VAC 50-60 Hz.

OUTPUT: Type – solid state switch. Rating – 60 watts maximum load per output.

PULSE WIDTH: Factory set at 100 milliseconds.

OFF TIME: Adjustable – 1 to 1.5 seconds minimum, 30 to 36 seconds maximum (factory set).

OPERATING TEMPERATURE RANGE: -10 to +130°F.

TRANSIENT VOLTAGE PROTECTION: 1000 volts for 8ms, 1% duty cycle.

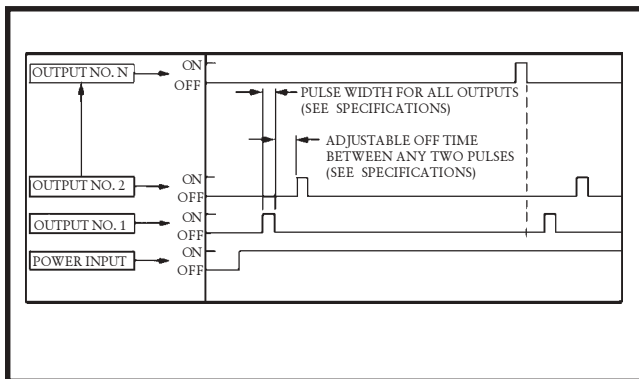

Figure 5
Operating Logic Diagram

AIR SUPPLY

NOTE

It is important that air supply be oil and moisture free. Contamination in the air used to clean filter elements will result in poor cleaning and loss in performance.

CAUTION

Purge air lines to remove debris before connecting to air manifold.

Remove plastic pipe cap from end of dust collector manifolds and connect air supply line. Use Teflon[®] tape on all air connections. Air valve, bleed type regulator and gage, filter and automatic condensate valve should be installed in the air supply line. These components should preferably be located in the building for convenient service and start-up/shutdown of the unit. See figure 2 – Typical Installation. Be sure that all components are adequately sized to meet system requirements.

OPERATION

START-UP

1. Turn air supply to air manifold on and adjust pressure to 90 psig. Experience indicates 90 psig to be the most typical setting for satisfactory cleaning performance. See Operating Adjustments below.
2. Turn on Hopper Discharge System (where so equipped and if on separate control). Hopper Discharge System must always be operating while dust collector is operating.
3. Turn on blower. At initial start-up, visually check blower rotation to be sure it is correct.
4. Adjust for proper air flow with volume control damper.

® – Dupont Trademark

OPERATING CHECKS

Monitor exhaust. Exhaust should remain visually clean. If a leak develops, it will be first noticed as a puff of dust immediately after a cleaning pulse. Monitor pressure drop. Equilibrium ΔP^* is generally 3-4 inches on magnehelic gage for seasoned filters, but 1-6 inches is considered normal.

OPERATING ADJUSTMENTS

Compressed air is specified at a pressure of 90 psig. The control timer is factory set to clean a segment of elements every 10 seconds.

Higher than design ΔP can often be lowered by increasing the frequency of cleaning. Minimum dwell time between pulses is 3 seconds. Additional cleaning energy may be obtained by adjusting pressure up to a maximum of 100 psig. DO NOT increase or decrease the length of pulse.

Longer pulses do not aid cleaning. They simply waste compressed air.

DO NOT increase air pressure beyond 100 psig. Damage may result.

* ΔP = Pressure drop across filter elements.

A low ΔP can be raised to design levels by increasing dwell time between pulses. Pressure switch control (Photohelic) may be added to clean only when ΔP reaches design level.

NOTE

At initial start-up with new filter elements, the fan motor may overload because of airflow higher than design level. If this happens, partially close a volume control damper.

SERVICE

CAUTION

- Disconnect electrical power before servicing any electrical components.
- Shut off and bleed compressed air supply before servicing any compressed air circuits.
- No welding should be performed inside unit without fire protection measures in use.

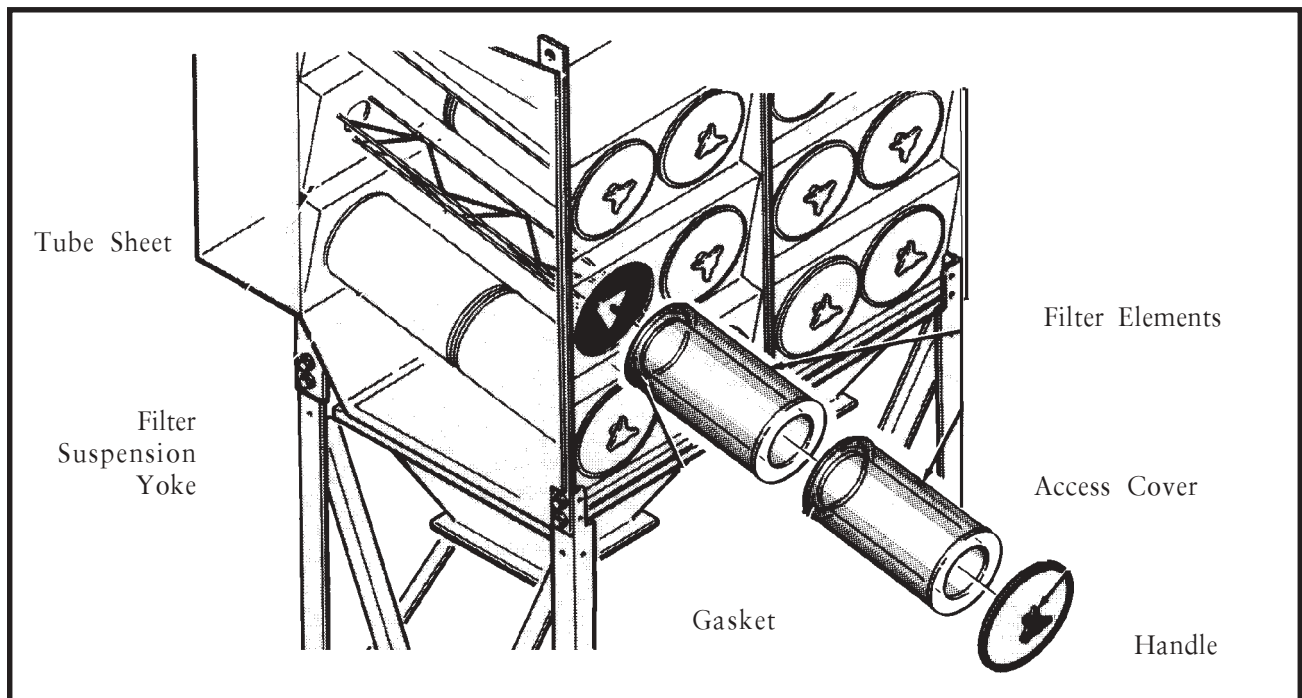

Figure 6
Filter Element Replacement

FILTER ELEMENT REMOVAL/ INSTALLATION

(See Figure 6 – Filter Element Replacement)

1. When changing element sets, start at the top of the unit. This ensures that the new, clean elements will not be contaminated by subsequent filter removals.
2. Access covers – Remove access covers by unscrewing the handles. Covers and handles can be placed out of the way.
3. Move filters to break gasket seal between filters and tube plate. Rotate filters 1/4 turn to dump any loose dirt off the top of the filter. Slide filters out of the collector on their suspension yokes.

The filters may be captured in plastic bags (not supplied) as they are removed.
4. Inspection – Inspect the tube sheet to make sure the gasket seating area is free of dust. IT IS NECESSARY TO BRUSH DUST OFF THIS AREA TO ENSURE A POSITIVE SEAL.
5. Installation – Slide two filter elements on the yoke **gasket end first**, wipe off the cover gaskets and install the access cover and handle. Tighten the handle end tight – DO NOT use a wrench.

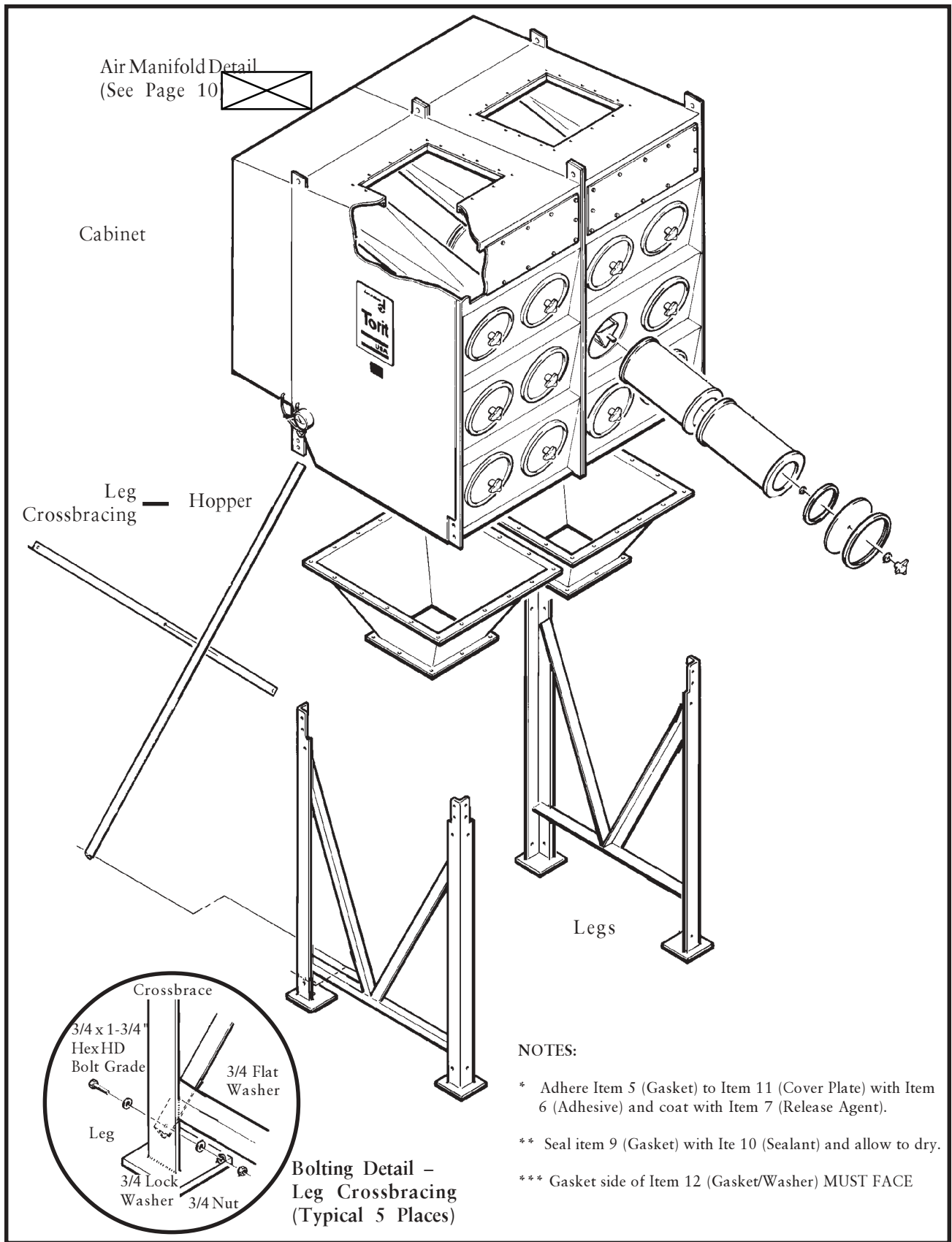

Parts Drawing 1
Downflo Dust Collector

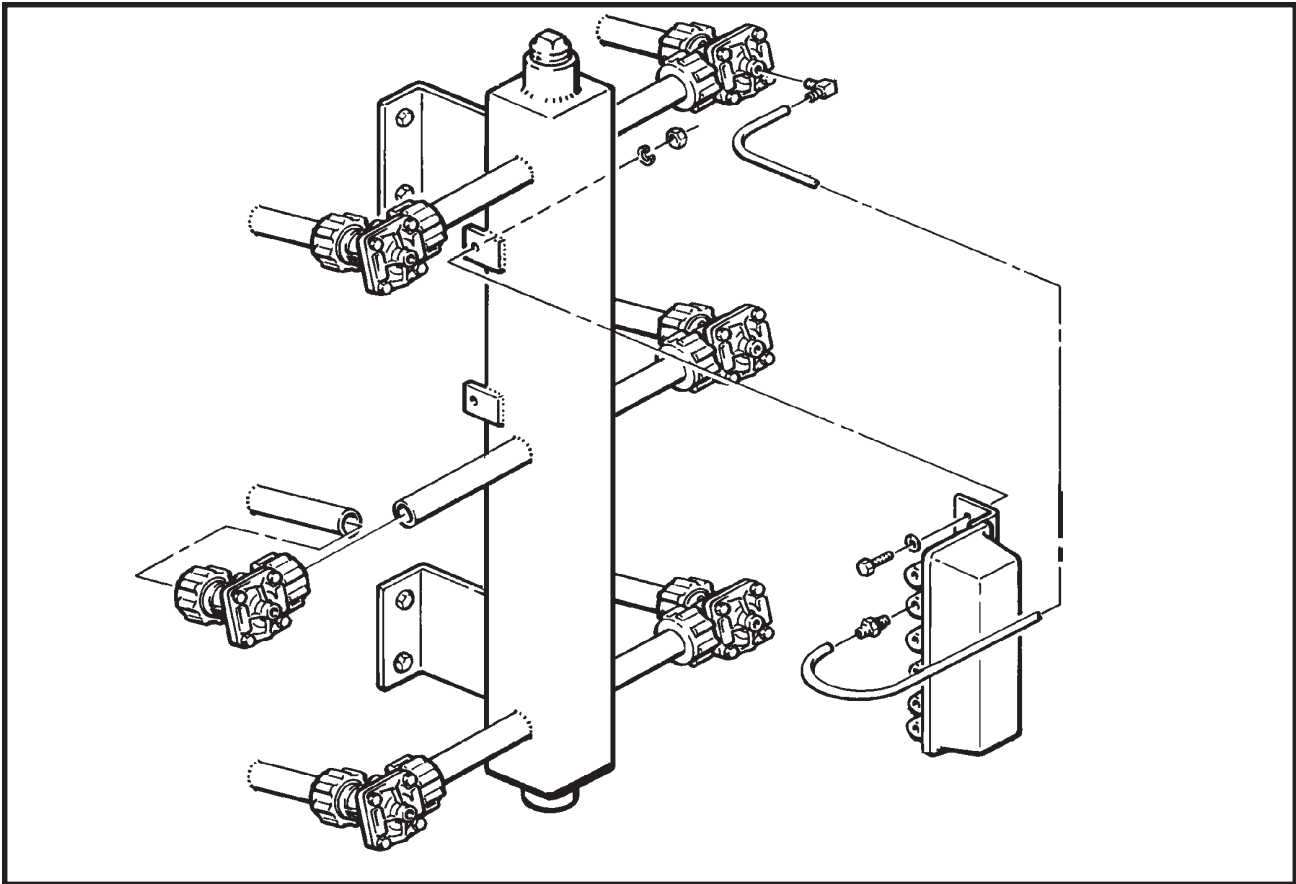

Parts Drawing 2
Air Manifold Detail

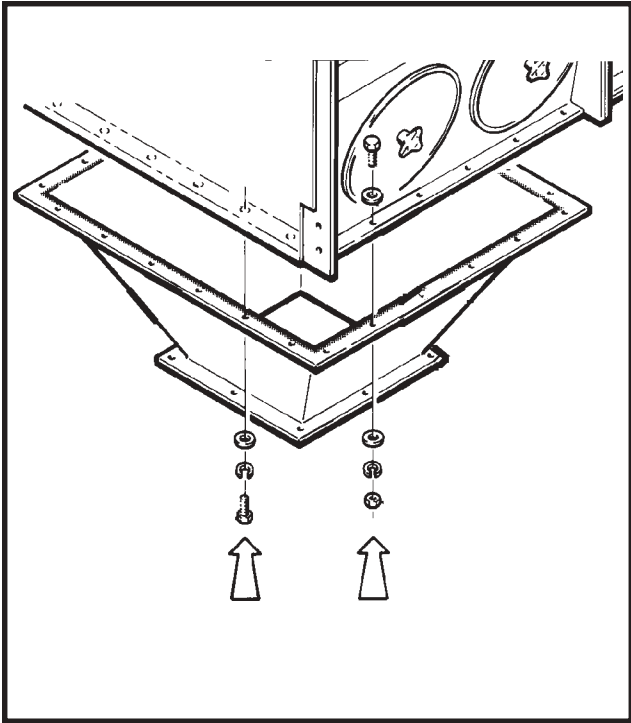

Parts Drawing 3
Bolting Detail – Hopper to Cabinet

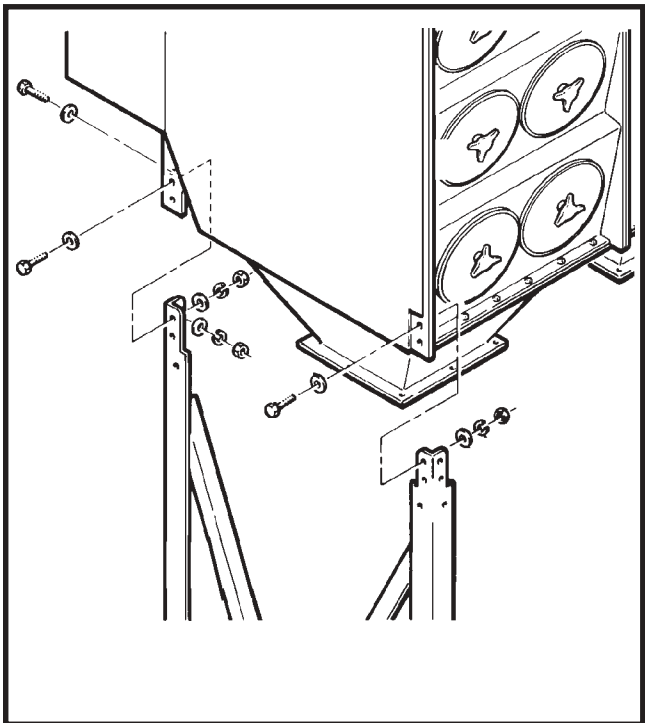

Parts Drawing 4
Bolting Detail – Legs to Cabinet

REPLACEMENT PARTS LIST

| REF. NO. | PART NO. | DESCRIPTION | QUANTITY |
|-------------|--------------|--|----------|
| 1 | 8PP-22114-01 | Nameplate, Torit: 12" x 18" | 1 |
| 2 | 8PP-11041-00 | Plate, serial number | 1 |
| 3 | 8PP-12537-00 | Rivet, blind; 5/32 dia. | 8 |
| 4 | | Filter element, cartridge | A/R |
| 5 | 8PP-22424-00 | Gasket, 3/8 x 1/2 x 10.12" I.D. | A/R |
| 6 | 8PP-18426-00 | Adhesive, 3M 847 | A/R |
| 7 | 8PP-18815-00 | Release Agent, mold type..... | A/R |
| 8 | 8PP-22422-00 | Clip: .688 ID | A/R |
| *9 | 8PP-25609-00 | Gasket, cover access | A/R |
| 10 | 8PP-16562-00 | Sealant, silicone tube..... | A/R |
| *11 | 6MM-40632-00 | Cover Plate, filter access, DF | A/R |
| 12 | 8PP-22423-00 | Gasket, washer: .81ID | A/R |
| 13 | 3EA-22427-00 | Knob, 3 lobe assy. | A/R |
| *14 | 8PP-21462-00 | Elbow, male; 1/4 OD to 1/8 NPT | A/R |
| *15 | 8PP-21462-00 | Connector, male; 1/4 OD to 1/8 NPT | A/R |
| 16 | 8PP-17986-00 | Locktite, pipe sealer | A/R |
| *17 | 8PP-21464-00 | Tubing, 1/4 OD | A/R |
| *18 | 8PP-24636-00 | Solenoid Valve Rebuild Kit | A/R |
| *18 | 8PP-25409-00 | Replacement Coil | A/R |
| *19 | 8PP-24277-00 | Diaphragm Valve, RCA 25DD | A/R |
| *21 | 4MA-22243-00 | Manifold Weldment (2DF8) | 1 |
| *21 | 4MA-22243-00 | Manifold Weldment (2DF16) | 2 |
| *21 | 4MA-22297-00 | Manifold Weldment (2DF12) | 1 |
| *21 | 4MA-22242-00 | Manifold Weldment (3DF24) | 2 |
| *21 | 4MA-22242-00 | Manifold Weldment (3DF36) | 3 |
| *21 | 4MA-22242-00 | Manifold Weldment (3DF60) | 5 |
| *21 | 4MA-22242-00 | Manifold Weldment (3DF72) | 6 |
| *21 | 4MA-22241-00 | Manifold Weldment (4DF32) | 2 |
| *21 | 4MA-22241-00 | Manifold Weldment (4DF48) | 3 |
| *21 | 4MA-22241-00 | Manifold Weldment (4DF64) | 4 |
| *21 | 4MA-22241-00 | Manifold Weldment (4DF80) | 5 |
| 22 | 6MM-22341-00 | Panel Deflector | A/R |
| 23 | 2SG-23339-00 | Magnehelic Pack | 1 |
| 24 | 3EA-22438-00 | Control Timer, solid state; 120 VAC, 50-60 Hz (not shown) | 1 |
| 25 | 8PP-22551-00 | Solenoid, Replacement..... | A/R |

*Replacement parts for units built after July, 1990.

THE TORIT DIVISION WARRANTY

TORIT hereby warrants that it will replace free of charge f.o.b. its factory at Baldwin, Wisconsin, such products furnished by TORIT as were manufactured by TORIT and as are, or become, defective within one year after date of shipment because of defects of material or workmanship provided, after notice to TORIT and its written consent thereto, the product is shipped prepaid to TORIT at Baldwin, Wisconsin, and provided the parts in question, prove to the satisfaction of TORIT, to be defective because of defects of material and workmanship. This warranty does not apply to or include the cost of removal of any part and the cost of installation of any replacement part. This warranty is in lieu of all and other warranties of any kind, expressed or implied, and of any other liability or obligation on the part of TORIT.

torit  **donaldson** Parts and Service Program
For genuine TORIT replacement filters and parts, call the TORIT EXPRESS Line:
1-800-365-1331

PARTS ORDERING INFORMATION

When ordering parts, give model number and serial number, part number, description and quantity of parts desired.



Donaldson Company, Inc.
Donaldson Industrial Group
P.O. Box 1299
Minneapolis, Minnesota 55440

*TORIT – The Industrial Air Pollution
Problem Solvers*